

Parilla GAZELLE 60cc TaG - CH

		FEATURES - CARACTERISTIQUES	
		Cylinder volume <i>Volume du cylindre</i>	59.42 cm ³
		Bore <i>Alésage</i>	41.80 mm
		Max. theoretical bore <i>Alésage théorique max.</i>	42 mm
		Stroke <i>Course</i>	43.30 mm
		Cooling system <i>Système de refroidissement</i>	Air
		Inlet system <i>Système d'admission</i>	Piston valve <i>Jupe de piston</i>
		Number of carbs <i>Nombre de carburateurs</i>	1
IBEA Carb. <i>Carburateur IBEA</i>	Gazelle 19.8mm	Cylinder/crankcase transfers n° <i>N° de canaux cylindre/carter</i>	2
Number of piston rings <i>Nombre de segments</i>	1	Inlet/exhaust ports number <i>N° lumières admiss./échapp.</i>	1 / 2
Big end conr. ball-bearing diam. <i>Diamètre palier tête de bielle</i>	18x24x15	Combustion chamber shape <i>Forme chambre de combustion</i>	Spherical <i>Spherique</i>
Crankshaft ball-bearing diam. <i>Diamètre palier du vilebrequin</i>	20x47x14	Selettra ignition <i>Allumage Selettra</i>	4 poles <i>4 pôles</i>
Small end conr. ball-bearing diam. <i>Diamètre palier pied de bielle</i>	12x16x16	Distance between Conrod centers <i>Longueur (entre axe) de la bielle</i>	96 mm

DESCRIPTION OF THE MATERIAL <i>DESCRIPTION DES MATERIAUX</i>		PISTON
Conrod material <i>Matériel de la bielle</i>	Steel <i>Acier</i>	
Crankshaft material <i>Matériel du vilebrequin</i>	Steel <i>Acier</i>	
Head material <i>Matériel de la culasse</i>	Aluminium	
Cylinder material <i>Matériel du cylindre</i>	Aluminium	
Liner material <i>Matériel de la chemise</i>	Iron <i>Fonte</i>	
DISTANCE BETWEEN CONROD CENTERS <i>ENTRE AXE DE LA BIELLE</i>		
Crankcase material <i>Matériel du carter</i>	Aluminium	
Piston material <i>Matériel du piston</i>	Aluminium	
Piston rings material <i>Matériel des segments</i>	Iron <i>Fonte</i>	
Exhaust muffler material <i>Matériel du pot d'échappement</i>	Sheet-steel <i>Tôle acier</i>	
Ball-bearings <i>Roulements</i>	6204 type	

CRANKSHAFT - VILEBREQUIN

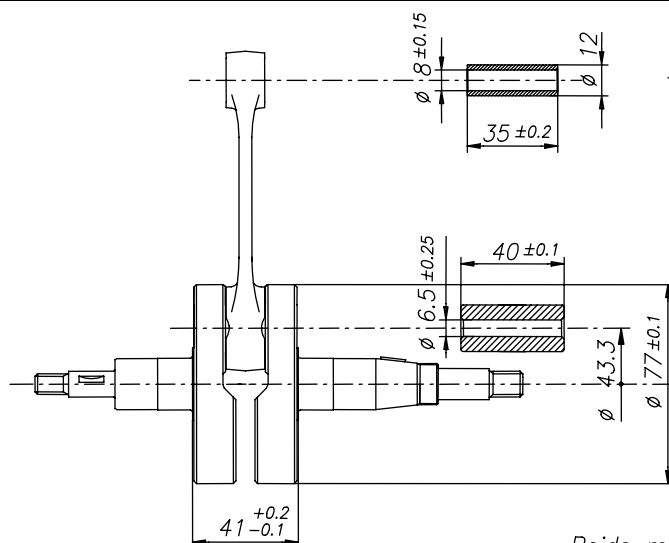

Poids min. de l'axe de piston 15.5 g
Piston pin min. weight 15.5 g

Poids min. du vilebrequin complet 1280 g
Complete crankshaft min. weight 1280 g

CYLINDER DEVELOPMENT - DEVELOPPEMENT DU CYLINDRE

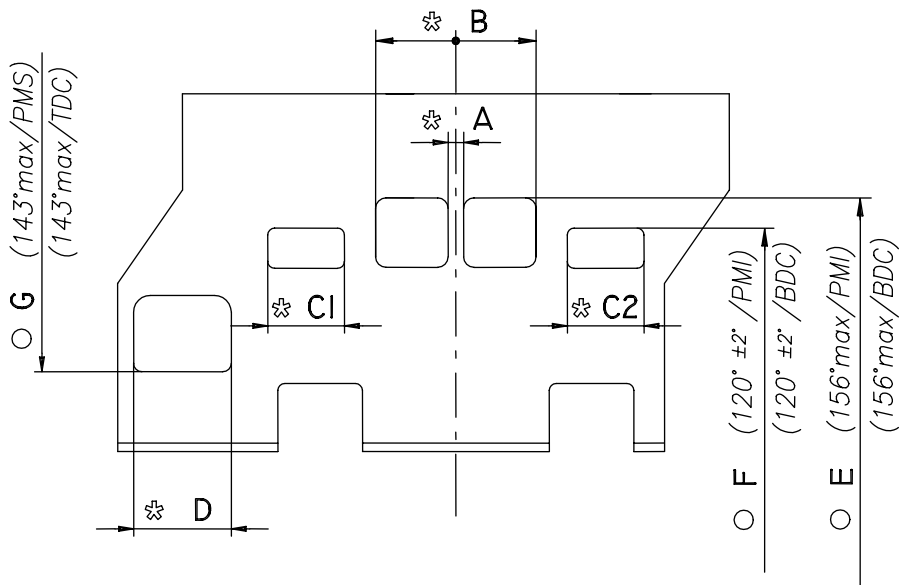

A	≥ 3.8 mm
B	≤ 34.5 mm
C1 = C2	≤ 18.5 mm
D	≤ 25.5 mm
E	156° max
F	120° ± 2°
G	143° max

\ast LECTURE CORDALE
 CHORDAL READING

\circ LECTURE ANGULAIRE PAR INSERTION D'UNE CALE DE 0.2 mm
 ANGULAR READING BY INSERTING A 0.2 mm GAUGE

CYLINDER BASE VIEW VUE DE LA BASE DU CYLINDRE

CYLINDER CROSS SECTION VIEW VUE EN SECTION DU CYLINDRE

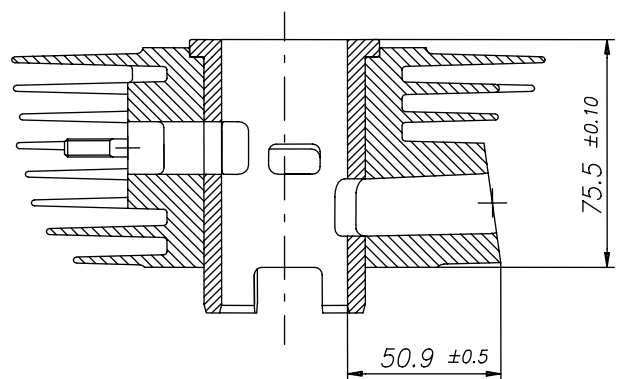
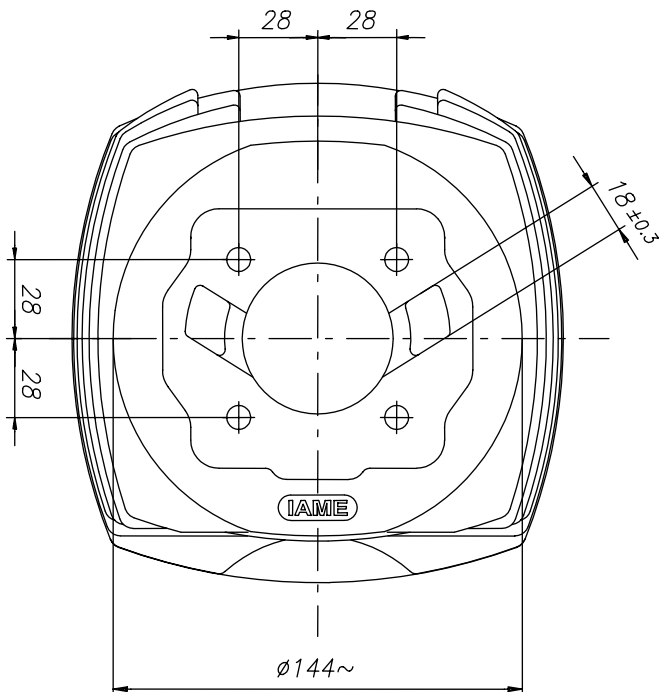

COMBUSTION CHAMBER VIEW
VUE DE LA CHAMBRE DE COMPRESSION

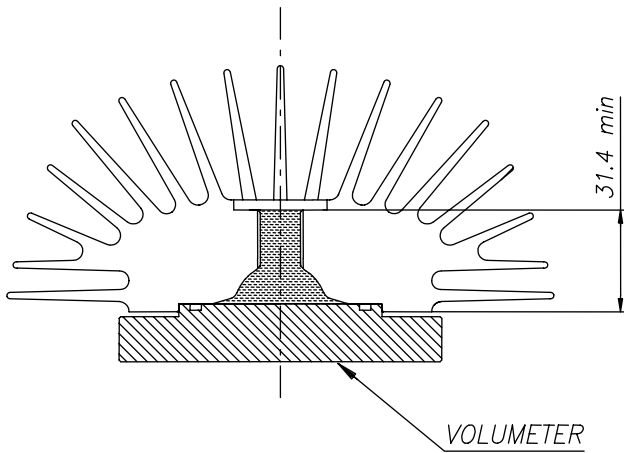

VOLUME CHAMBRE COMBUSTION = 7.7 cm³ min.
 COMBUSTION CHAMBER VOLUME = 7.7 cm³ min.

CRANKCASE INSIDE VIEW
VUE A' L' INTERIEUR DU CARTER

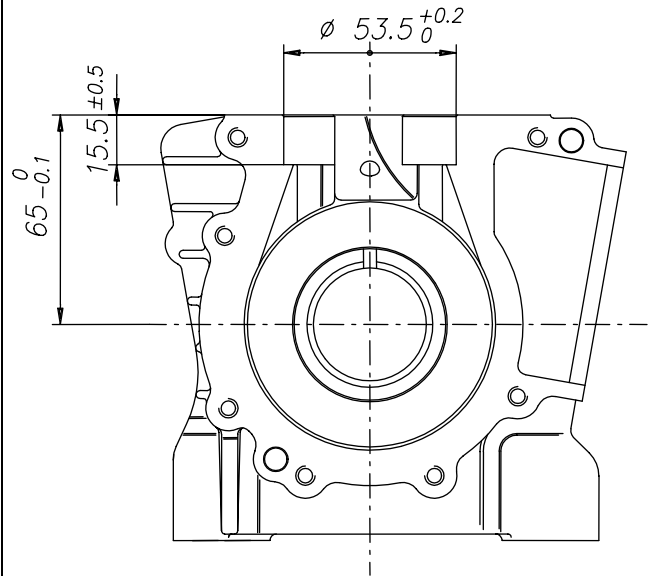

VENTURI CARB. DIMENSIONS
DIMENSIONS DU VENTURI DU CARBURATEUR

IBEA mod. Gazelle 19.8mm

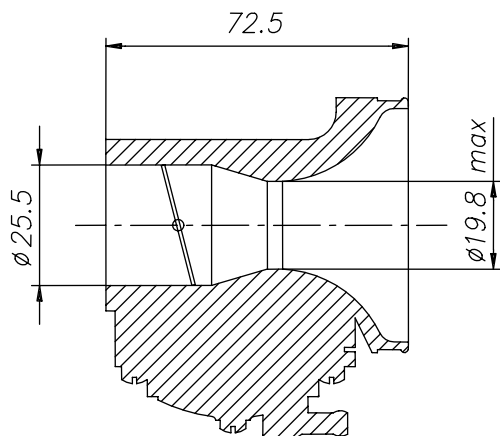

INLET SILENCER
SILENCIEUX D'ASPIRATION

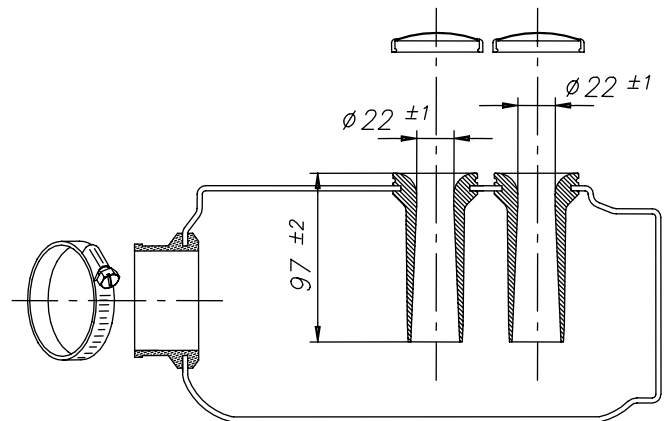

FREE LINE mod. AL-22-PS exclusivement
FREE LINE mod. AL-22-PS only

DESCRIPTION OF THE CLUTCH - DESCRIPTION DE L' EMBRAYAGE

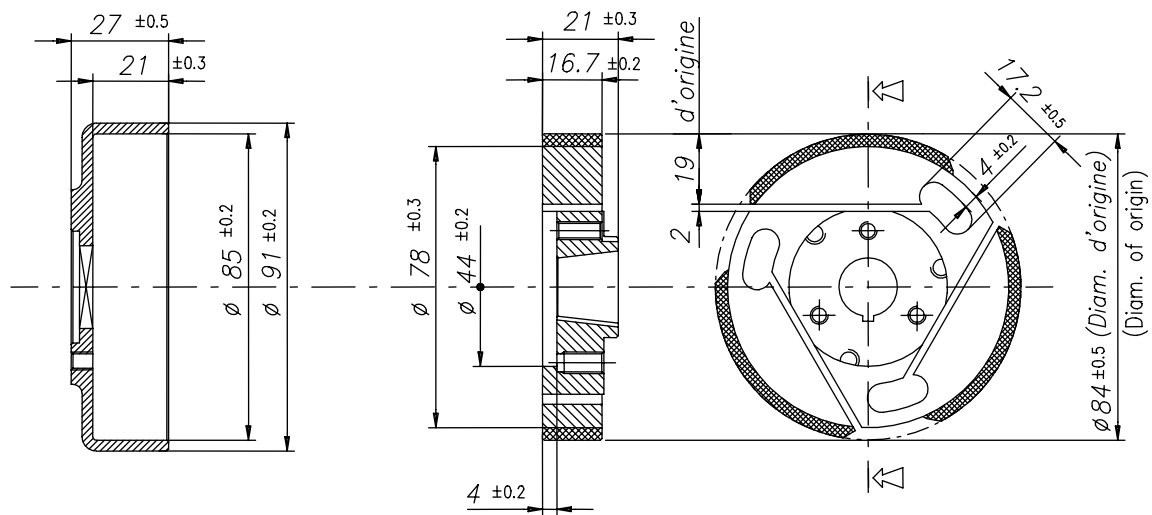
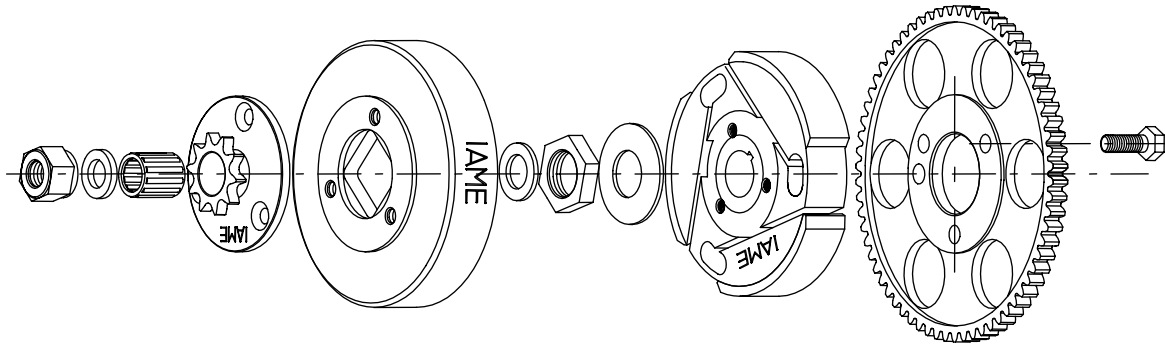

Poids min. 292 g
Min. weight 292 g

Poids min. 450 g
Min. weight 450 g

EXHAUST MUFFLER VIEW AND DIMENSIONS
VUE ET DIMENSIONS DU SILENCIEUX D' ECHAPPEMENT

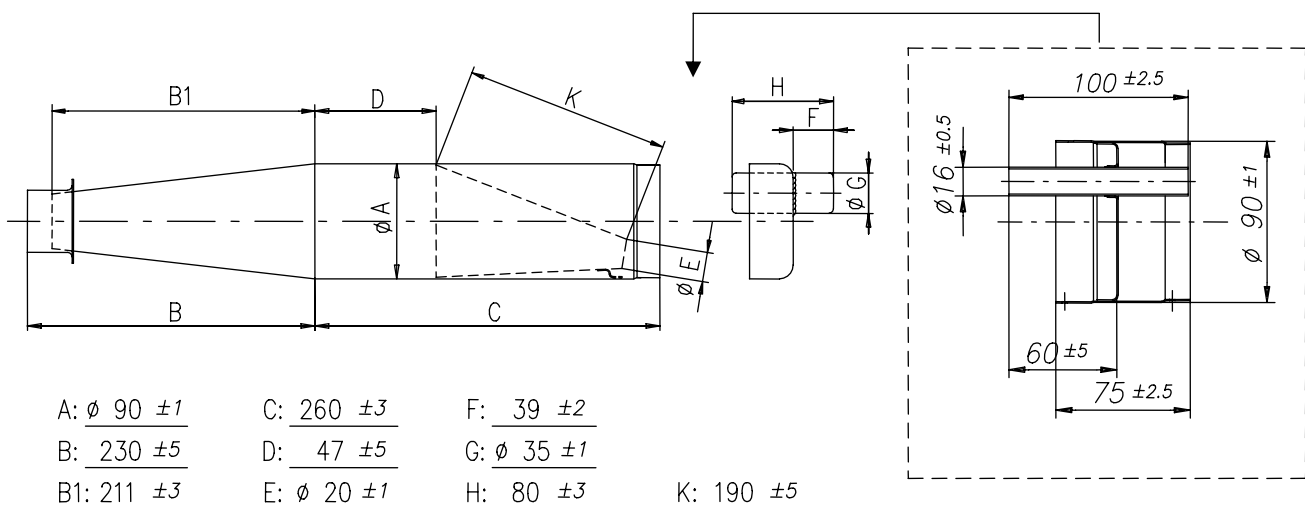

THERMIC INLET SPACER - JOINT THERMIQUE D' ADMISSION

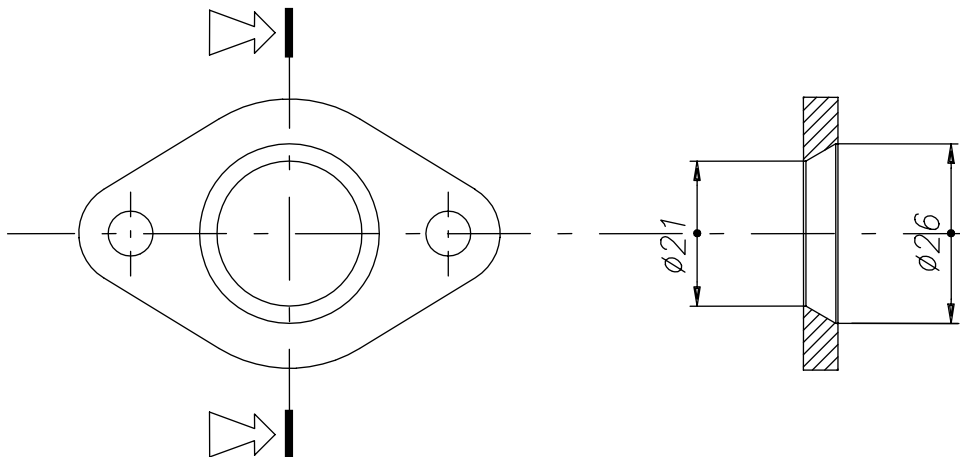

- THE GAZELLE 60cc ENGINE, IN THE "FREE" VERSION, IS PROVIDED, AT THE ORIGIN, EXCLUSIVELY, WITH THE THERMIC SPACER, WHOSE DIMENSIONS ARE SHOWN ON THE ABOVE DRAWING.
- *LE MOTEUR GAZELLE 60cc, MODELE "FREE", EST EQUIPE, A L' ORIGINE, EXCLUSIVEMENT, DU JOINT THERMIQUE, DONT LES DIMENSIONS SONT INDIQUEES SUR LE DESSIN.*

EXHAUST HEADER - COUR D' ECHAPPEMENT

