

ROTAX engines type**F_{ormula} R_{otax} 125 MAX****F_{ormula} R_{otax} 125 Junior MAX**

Engine configuration-no.: 37.125.1301 FR 125 MAX (= configuration 21 kW)

30.0125.130 FR 125 Junior MAX (= configuration 15 kW)

This technical specification should enable the technical commission to verify the original condition of the ROTAX engine type FR 125 MAX with configuration 21 kW and FR 125 Junior MAX with configuration 15 kW. By checking of these figures step by step the uniformity of the technical basis of the engine can be confirmed. It is up to the organiser of the competition which items are used for the respective reglement.

Only genuine ROTAX components that are specifically designed and supplied for the FR125 MAX and FR 125 Junior MAX engine are legal, unless otherwise specified.

Neither the engine nor any of its ancillaries may be modified in any way. "Modified" is defined as any change in form, content or function that represents a condition of difference from that originally designed. This is to include the addition and/or omission of parts and/or material from the engine package assembly unless specifically allowed within these rules. The adjustment of elements specifically designed for that purpose shall not be classified as modifications, i.e. carburetor and exhaust adjustment screws.

Internal additions: no additional material may be added except in the case of engine repairs and shall only restore the engine or components to original specifications. With the exception of the gilnisil coating of the cylinder:

- The use of thermal barrier coatings/ceramic coatings on or in the engine and on or in the exhaust system is prohibited.
- The use of anti-friction coatings in or on the engine/engine components is prohibited.

Legal additions: Chainguard, engine mount, temperature gauge and tachometer/hour meter.

Non tech items: fasteners, circlips and washers are allowed unless otherwise specified.

		ITEM	CHECKED
SQUISH GAP:	FR 125 MAX: 0,90 mm – 1,50 mm	1.1	
	FR 125 Junior MAX: 1,20 mm – 1,80 mm	1.2	

<p>COMBUSTION CHAMBER INSERT:</p>	<p>Identification code has to be 223 389 (4).</p> <p>Name ROTAX has to be cast (5).</p> <p>Height of combustion chamber insert has to be 27,55 mm with a tolerance of +0,0/-0,1 mm (6), see illustration 1.</p> <p>The profile of the combustion chamber insert has to be checked with the combustion chamber insert template (ROTAX part no. 277 390). The crack of light between the template and the profile of the combustion chamber insert has to be the same over the whole profile.</p>	<p>2.1</p> <p>2.2</p> <p>2.3</p> <p>2.4</p>	
<p>PISTON:</p>	<p>Coated, aluminium, cast piston with one 1 mm-rectangular-piston ring. The piston has to show on the inside the words "ELKO" and "MADE IN AUSTRIA" in casting.</p> <p>Machined areas are: Top end of piston, outside diameter, groove for the piston ring, bore for piston pin, inside diameter at bottom end of piston. All other surfaces are not machined and have cast surface.</p>	<p>3.1</p> <p>3.2</p>	
<p>GUDGEON PIN</p>	<p>Gudgeon pin has to be made out of magnetic steel. Must be as per illustration 4.1</p>	<p>4.1</p>	
<p>CYLINDER:</p>	<p>Light-alloy-cylinder with GILNISIL-plating, configuration with one main exhaust port and pneumatic adjusted exhaust valve (exhaust valve for configuration FR 125 MAX only) Any replating is not allowed.</p> <p>Maximum bore: 54,035 mm (measured 10 mm above the exhaust port).</p> <p>Cylinder has to be marked with ROTAX-Logo (1), see illustration 2.</p>	<p>5.1</p> <p>5.2</p> <p>5.3</p>	

	<p>FR 125 MAX: Cylinder has to be marked with identification code. 223 997 (2), see illustration 2.</p> <p>FR 125 Junior MAX: Cylinder has to be marked with identification code. 223 999 (2), see illustration 2.</p> <p>Height of cylinder has to be 87 mm with a tolerance of $-0,05/+0,1$ mm (3), see illustration 3.</p> <p>All ports and passages are cast finish except some removal of flashing from inlet and exhaust port and passages. All ports have chamfered edges to prevent ring snagging. Any additional machining is not permitted.</p>	5.4	
		5.4	
		5.5	
		5.6	
INLET SYSTEM:	<p>Intake manifold is marked with the name ROTAX and the identification code 267 915. No grinding or machining is permitted.</p> <p>The reed valve assy is equipped with 2 petal stops and 2 reeds, each having 3 petals. The maximum allowable width between the inside faces of the 2 metal reed valve stops is 21,3 mm.</p> <p>The thickness of the reeds is 0,6 mm, \pm 0,08 mm.</p>	6.1	
		6.2	
		6.3	
EXHAUST POWERVALVE	<p>Configuration FR 125 MAX only! As supplied by the manufacturer with no modifications allowed. Spring must be fitted. Any external adjustment or blocking to this once the engine is running is illegal.</p>	7.1	
CRANKSHAFT:	<p>Stroke: 54,5mm \pm 0,1 mm</p> <p>Con rod (7) has to show forged number "213" or "365" on shaft (see ill. no. 4)</p> <p>Shaft of con rod is not machined (copper plated). Grinding or polishing of shaft of con rod is not permitted.</p>	8.1	
		8.2	
		8.3	

<p>BALANCE SHAFT</p>	<p>Balance shaft must be installed and operational.</p> <p>Different configurations of part no. 237 945 and 237 949 are legal (see ill. no. 4.2)</p> <p>Surface (1) is not machined and must be cast surface (see ill. no. 4.2).</p> <p>Measurement from centre of balance shaft to outer diameter of fly weight of balance shaft at a defined length must not be lower than specified (see ill. no. 4.2).</p> <p>The minimum weight of the dry balance shaft must not be lower than 355 gramme for balance shaft ROTAX part no. 237 945 and 255 gramme for balance shaft ROTAX part no. 237 949</p>	<p>9.1</p> <p>9.2</p> <p>9.3</p> <p>9.4</p> <p>9.5</p>	
<p>CRANKCASE</p>	<p>As supplied by the manufacturer. No grinding/polishing is permitted in the two main transfer passages.</p>	<p>10.1</p>	
<p>IGNITION UNIT:</p>	<p>DENSO digital battery ignition, variable ignition timing, no adjustment necessary and possible.</p> <p>The casing of the ignition coil has to show following castings "129000 -" and "DENSO". The ignition coil must show 3 pins at the terminal.</p> <p>Spark plug: DENSO Iridium IW... or NGK BR ... EG</p> <p>Original battery must be used, FIAMM-GS type FG 20651 or FG 20722</p> <p>Spark plug cap must be marked with "NGK TB05EMA".</p>	<p>11.1</p> <p>11.2</p> <p>11.3</p> <p>11.4</p> <p>11.5</p>	
<p>CARBURETOR:</p>	<p>DELL'ORTO carburetor</p>	<p>12.1</p>	

	<p>"VHSB 34" cast in the housing of the carburetor.</p> <p>"QD" stamped in the housing of the carburetor.</p> <p>The complete inlet bore in the casing of the carburettor must show cast surface</p> <p>Needle jet stamped with "FN 266"</p> <p>The carburetor slide must show with size "40" in casting and the bottom end of the slide must show cast surface.</p> <p>Jet needle stamped with "K27" only (will be made available as of beginning of 2002)</p> <p>Other setting of the carburettor is free. Main jets smaller than size 160 or bigger than 185 are not recommended by ROTAX and therefore not available as a replacement part from ROTAX. Main jets smaller than size 160 and bigger than 185 are legal also if they are not available from ROTAX.</p>	<p>12.2</p> <p>12.3</p> <p>12.4</p> <p>12.5</p> <p>12.6</p> <p>12.7</p> <p>12.8</p>	
FUEL PUMP:	MIKUNI diaphragm pump, placed on bottom of support bracket for intake silencer	13.1	
RADIATOR:	<p>Single aluminium radiator as shown in illustration 5.</p> <p>Cooling area: Height = 290 mm, width = 133 mm</p> <p>Thickness of radiator = 32 mm</p> <p>Place of fixing the radiator is on right side of engine.</p> <p>Radiator must be mounted with support bracket (5) and supporting rod (9), see illustration 5</p> <p>No additional cooling device is allowed.</p>	<p>14.1</p> <p>14.2</p> <p>14.3</p> <p>14.4</p> <p>14.5</p> <p>14.6</p>	
RADIATOR	As glycol coolants are not permitted, distilled	15.1	

COOLANT	water without any additives has to be used.		
CLUTCH:	Dry centrifugal clutch, engagement r.p.m. maximum at 3.000 r.p.m. That means, that the kart (without driver) must start to move latest at an engine speed of maximum 3.000 r.p.m.	16.1	
INTAKE SILENCER:	Intake silencer with integrated, washable air cleaner with all parts as shown at illustration 6, mounted on the support bracket. If the race is declared a "wet race" the position of the intake silencer is free . No modifications allowed. Air filter must be installed as shown in illustration 6.	17.1 17.2	

EXHAUST SYSTEM:	Must be as supplied by Rotax and cannot be modified except for the replacement of the silencer absorbtion material.	18.1	
	Standard engine/pipe coupling must be used.	18.2	
	Exhaust pipe with after muffler as shown in illustration 7:	18.3	
	length of inlet cone: Typ A and B: 592 mm \pm 5 mm (measured on outside from beginning of exhaust pipe until beginning of cylindrical part).	18.4	
	length of cylindrical part of exhaust pipe: Typ A and B: 125 mm \pm 5 mm.	18.5	
	length of end cone: Typ A: 250 mm \pm 5 mm, Typ B: 225 mm, \pm 5 mm (measurement, see illustration 8).	18.6	
	outside diameter of 180° bent tube: Typ A: 30mm +0,5 mm/-3 mm, Typ B: 41mm +1,5 mm/-1,0 mm (measured at beginning and end of bend).	18.7	
	Diameter of hole of end cap of (illustration 7, pos. 3 or 6): 21 mm +/- 0,2 mm.	18.8	
	Typ A and B: The expansion chamber and silencer supplied with the engine may not be modified, except for the addition of extra elements to further reduce noise levels.	18.9	

NOISE EMISSIONS:	<p>Noise isolating mat (illustration 7, pos. 3) has to be replaced by a original ROTAX spare part, if the noise emission is exceeding 92 dB (A).</p> <p>Noise emission measuring procedure:</p> <ul style="list-style-type: none">• The measuring place has to be at section of the track where the engine is operated under full load and at a rpm range of 11.000 to 12.000 rpm.• The microphone has to be installed 1 meter above the level of the track in a rectangular angle to the track.• The distance between the microphone and the kart on the ideal line on the track has to be 7,5 meters.• The kart has to be operated under full load at the ideal line on the track.	19.1	
---------------------	---	------	--

FOR INFORMATION ONLY
WITHOUT COMMITMENT TO ADVISE

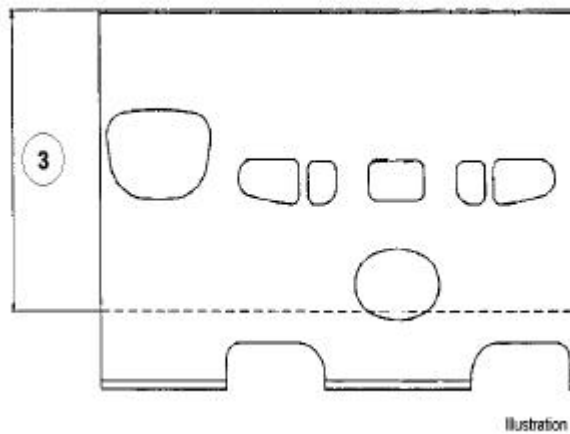
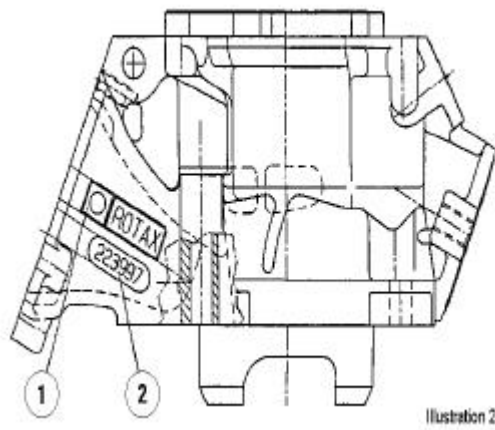
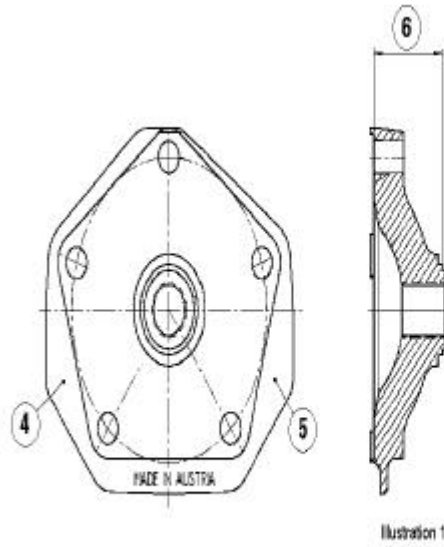

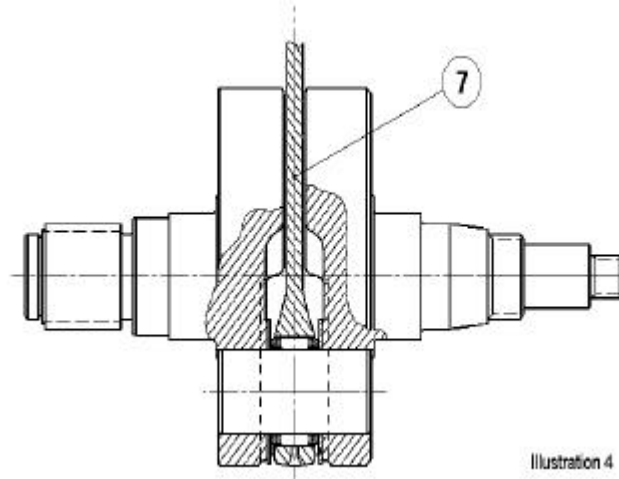

Illustration 4

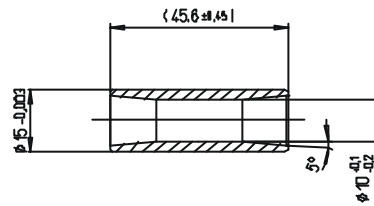

Illustration 4.1

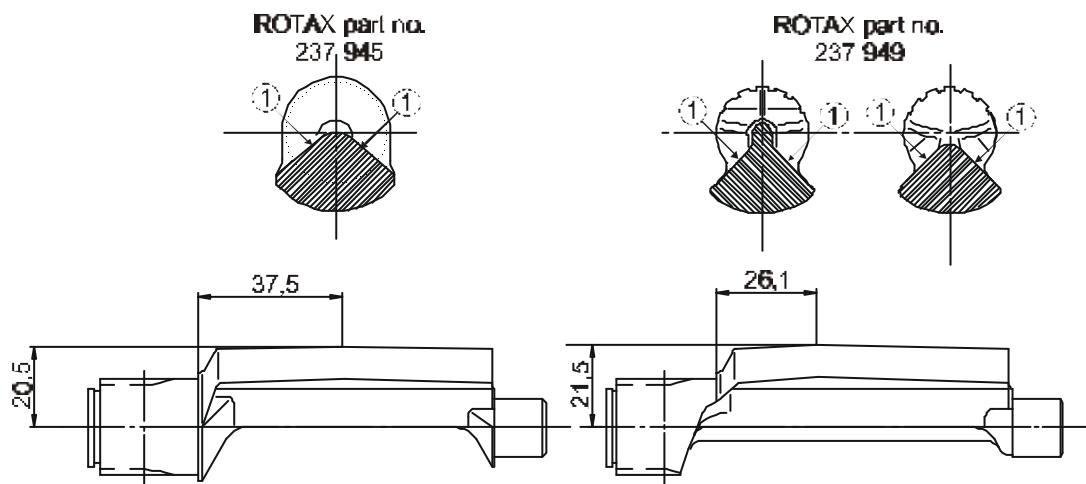
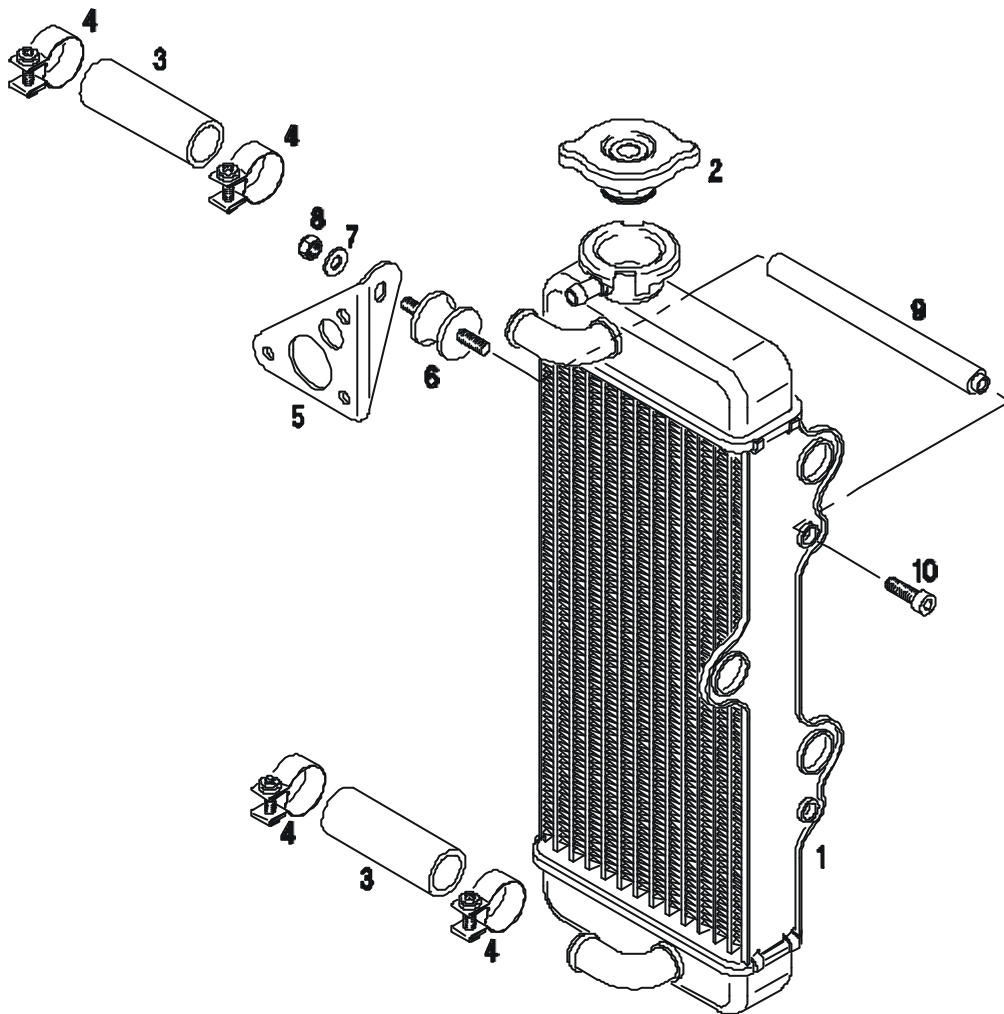

Illustration 4.2

**Illustration 5**

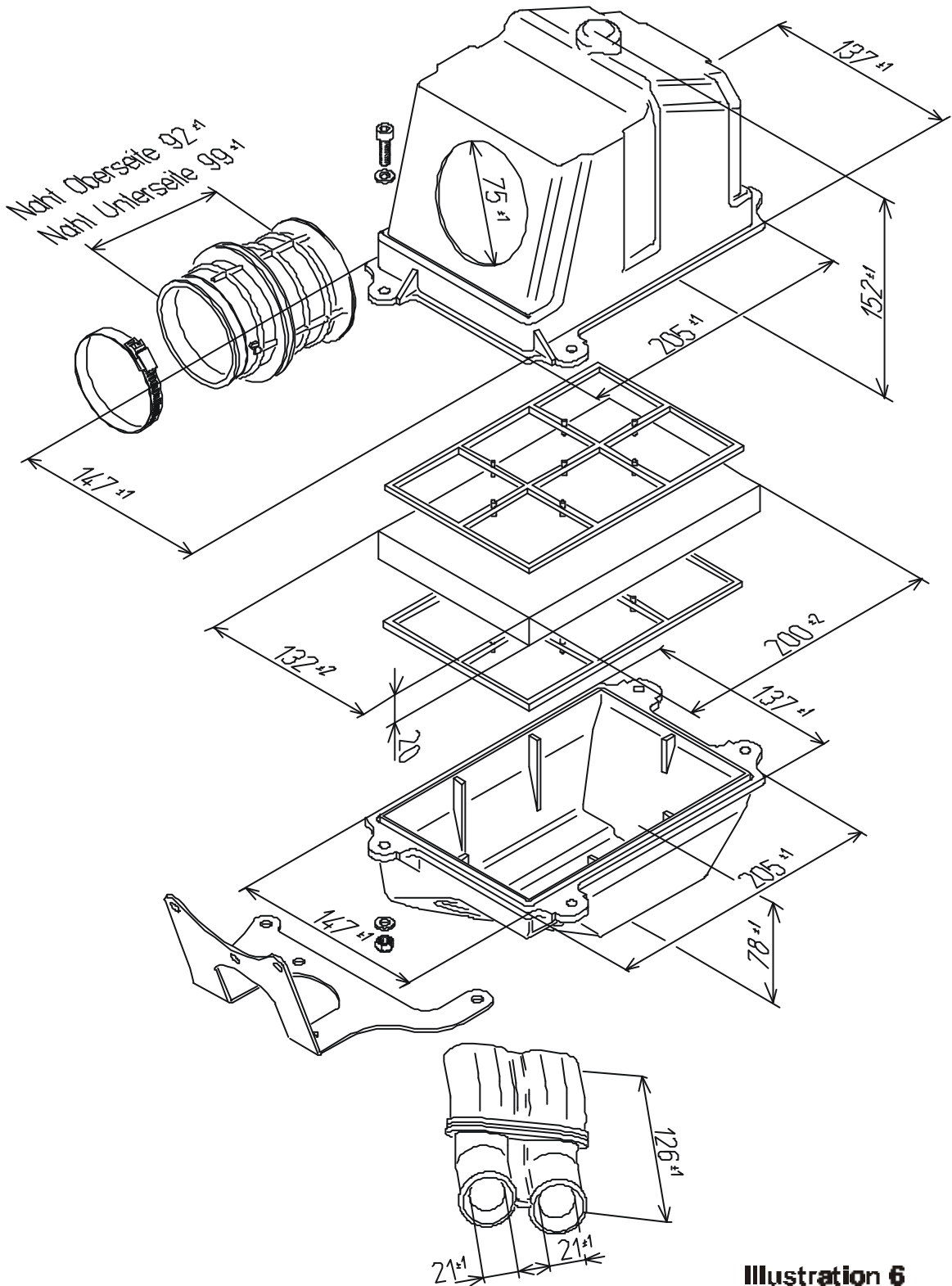

Illustration 6

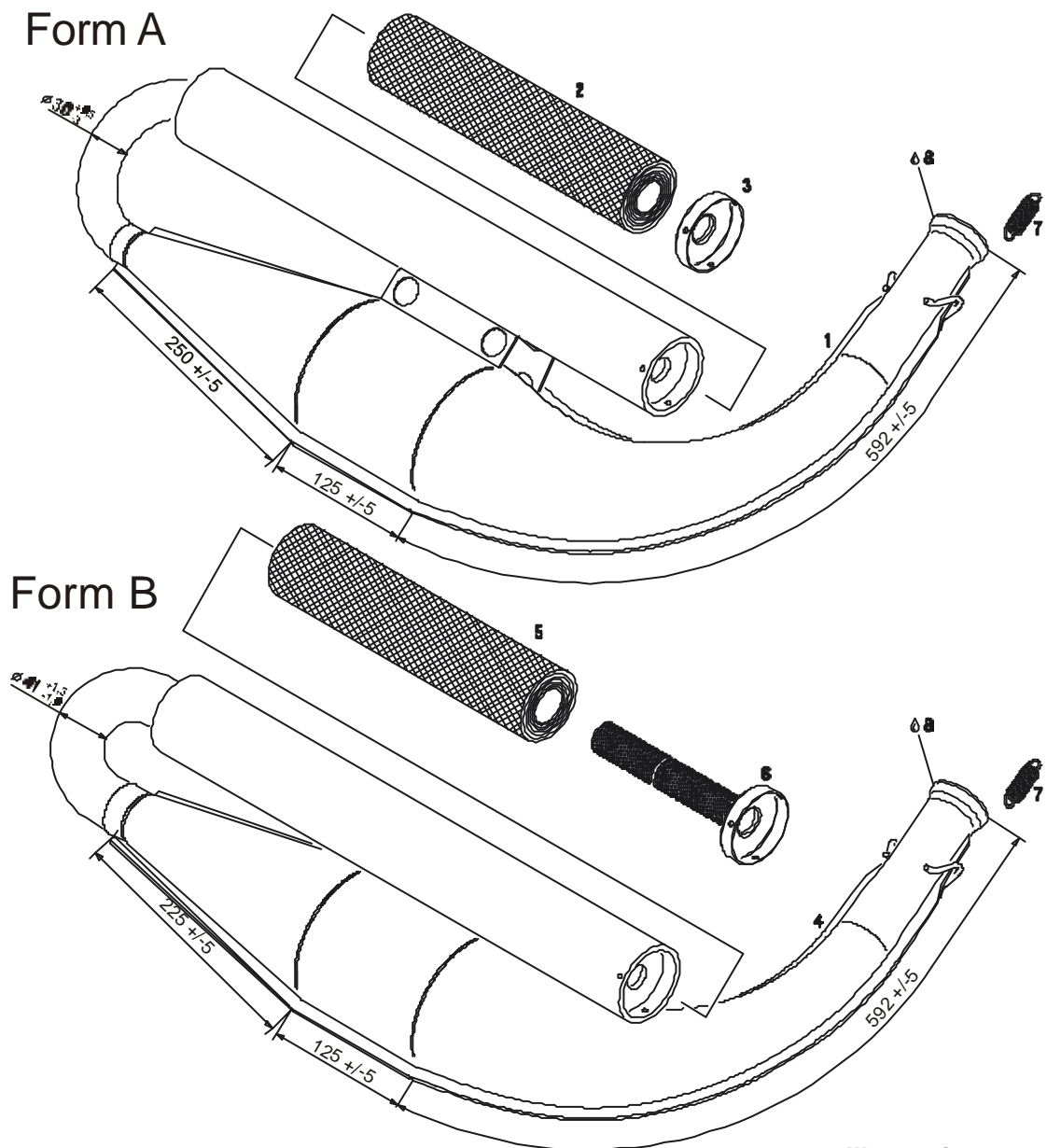

Illustration 7